

Quick Clip (QC-01)

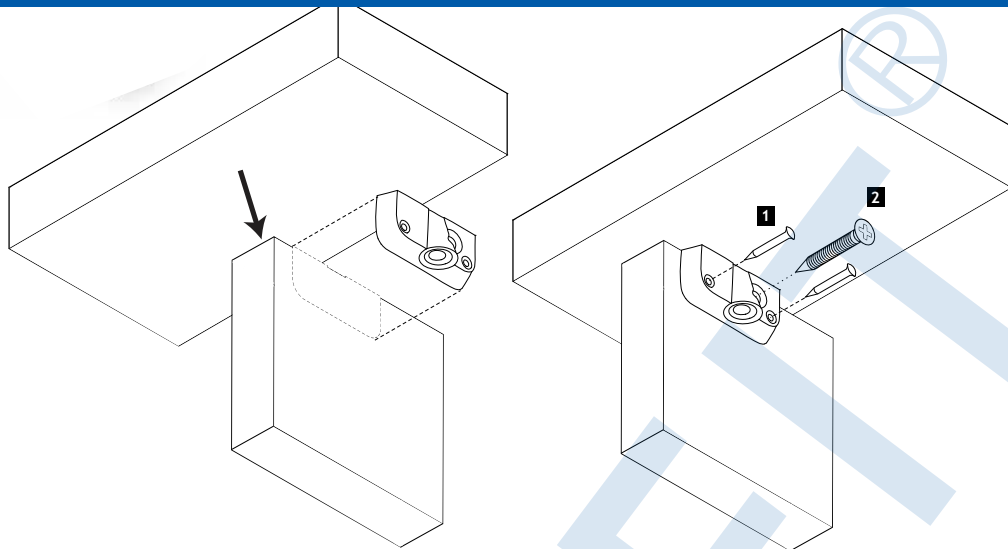

NAME:

Quick Clip - fitting instructions

PAGE:

1 of 3

DESCRIPTION:

Quick clip comes with 1.) zinc-plated nails in place ready for attaching 2.) (Optional) Utilising the #6 (3.5mm) screw hole in the direction of the nails, the Quick Clip becomes an all round component connector.

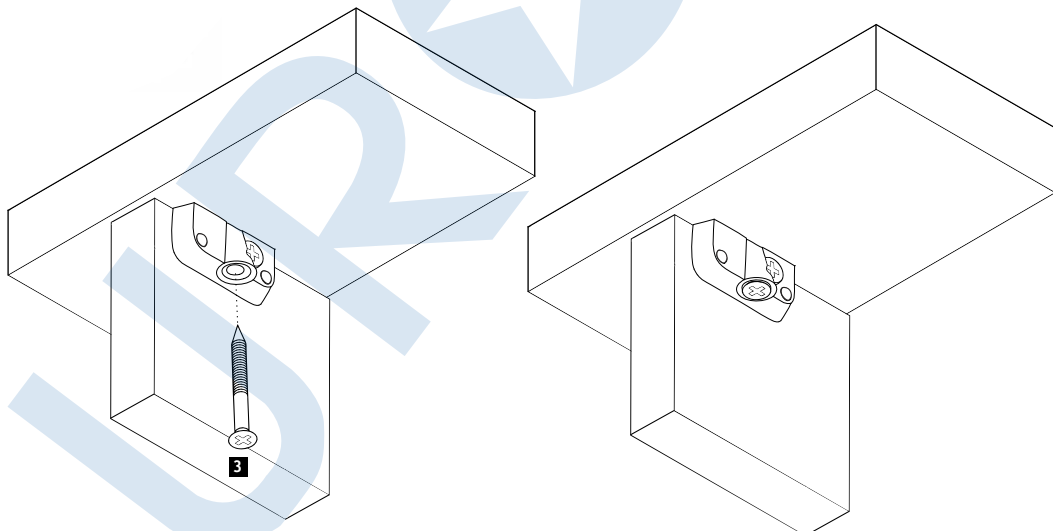

NAME:

Quick Clip - fitting instructions

PAGE:

2 of 3

DESCRIPTION:

3.) The #8 (4mm) screw hole has been angled for ease of screwing providing side clearance for drill, power screwdriver and knuckles.

Quick Clip (QC-01)

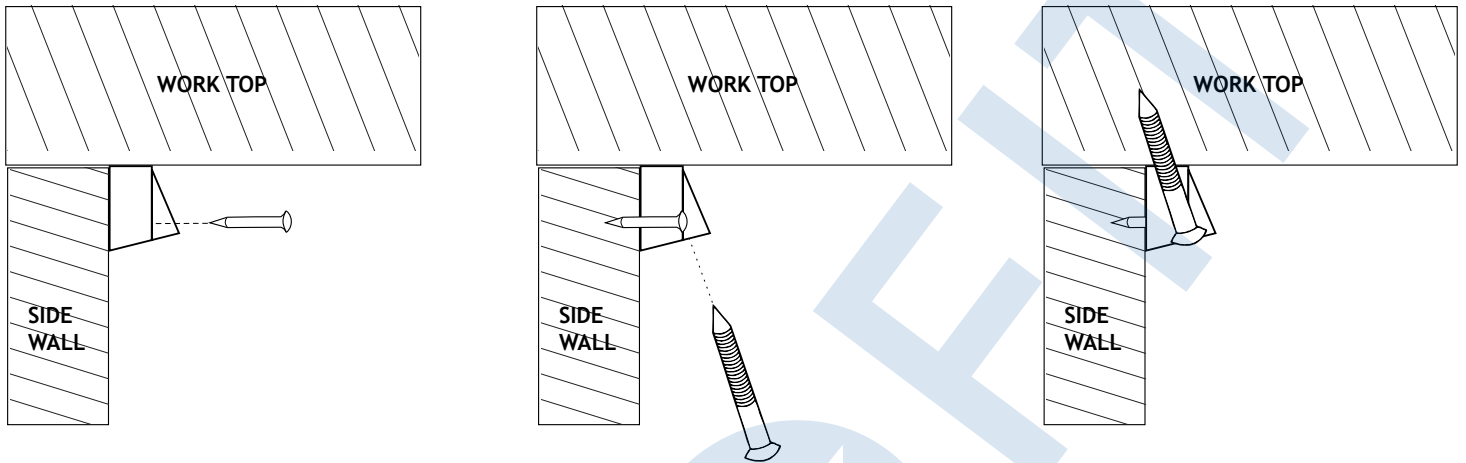

NAME:

Quick Clip - fitting instructions

PAGE:

3 of 3

DESCRIPTION:

Using the Quick Clip for attaching panels will often reduce the need for back rails. It will be particularly suitable for one-off constructions saving multi borer set-up and also as a back up when multi boring has not been anticipated.